

B METERS



UNI EN ISO 6817

mod. MAG-C



Ko-Ka Ky

Elettromagnetic flowmeter



Il misuratore di portata elettromagnetico mod. Mag-C è stato progettato per misurare portate e volumi di liquidi elettricamente conduttori.

L'innovativa gestione del segnale generato dagli elettrodi consente di effettuare misurazioni molto accurate in un campo vastissimo di portate.

Questi misuratori di portata non contengono parti mobili meccaniche e quindi il liquido non incontra ostacoli durante il passaggio, evitando così possibili danni causati da detriti solidi presenti nel liquido.

L'interno del tubo di misura è isolato elettricamente, pertanto il liquido di processo non viene mai in contatto né con il materiale del tubo di passaggio né con quello delle flange. Questo permette la misura di qualsiasi tipo di liquido compatibile con il rivestimento interno.

Tutti i valori misurati e tutti i dati di configurazione vengono memorizzati su memoria interna per evitare la loro perdita nel caso di una interruzione dell'alimentazione.

Queste sue caratteristiche unite alla bassissima perdita di carico ed il possibile montaggio in tutte le posizioni, rendono il suo utilizzo adatto ai più svariati settori dell'industria chimica di processo, cartaria, alimentare e agli impianti idrici.

I 3 elettrodi interni permettono di avere errori inferiori al 0,2% per velocità di liquido comprese fra 0,2 m/s e 10 m/s e di avere un segnale di allarme in caso di tubo non pieno.



The electro-magnetic flow meter model MAG-C has been engineered so to measure the flow and the volume of any liquid that is electrically conductor.

The very new management system of the signal generated by the electrodes allows a very accurate measurements in a very vast flows field.

Those flow meters do not have any mechanical moving component, and therefore the liquid do not have any obstacle in its flowing, thus avoiding any damage caused by solids that can be in the liquid.

The internal part of the measuring pipe is electrically insulated and therefore the liquid to be measured does not have any possibility to be in contact with the material by which the pipe and the flanges are made.

That allows the possibility of measuring any type of liquid compatible with the internal cladding.

All the measured data and all the set-up data are memorized on the internal memory so to avoid accidental loss in case of a power black out.

The MAG-C meters enjoys a very low head of loss and the possibility of mounting in every position, and therefore are suitable for every sector of the chemical, paper, food industries and water works.

The 3 internal electrodes allows to have errors up to 0.2% for liquid speed from 0.2 m/s to 10 m/s, and an alarm signal for empty pipe is also included.



El medidor de caudal electromagnético mod. Mag-C se ha proyectado para medir caudales y volúmenes de líquidos eléctricamente conductores.

La innovadora gestión de señales generadas desde los electrodos permite efectuar una medición esmerada dentro de un amplísimo campo de caudales.

Estos medidores de caudales no contienen partes mecánicas móviles y, por tanto, el líquido no encuentra obstáculos durante su paso, evitando así posibles daños causados por detritus sólidos presentes en el fluido.

El interior del tubo de medida está aislado eléctricamente, por lo tanto el líquido procesado no está nunca en contacto, ni con el material del tubo de paso, ni con el de las bridas. Esto permite la medición de cualquier tipo de líquido compatible con el revestimiento interno.

Todos los valores medidos y todos los datos de configuración vienen memorizados en la memoria interna para evitar su pérdida en caso de una interrupción de la alimentación eléctrica.

Estas características, unidas a la bajísima pérdida de carga y la posibilidad de montaje en cualquier posición, permiten su uso apto a los más variados sectores de la industria química de desarrollo, papelera, alimentaria, y a las instalaciones de recursos hídricos.

Los 3 electrodos internos permiten tener errores inferiores al 0,2 % para velocidades del líquido comprendidas entre 0,2 m/s. y 10 m/s. y de disponer de una señal de alarma en caso que el tubo esté poco lleno o vacío.

HYW bJW XUJ

Available diameters	25	32	40	50	65	80	100	125	150	200	250	300	350	400			
	1"	1.1/4"	1.1/2"	2"	2.1/2"	3"	4"	5"	6"	8"				10"	12"	14"	16"
Standard flanged connections	UNI 2223																
Standard operation pressure	PN 16 (16bar) (PN25 - PN40 su richiesta) PN 16 (16bar) (PN25 - PN40 on request)																
Flanged connections on request	ANSI 150	ANSI 300	DIN 2501	BS45404	AWWA	ISO 7005	KS	su richiesta on request									
Max error ready flow rate	0.2%																
Max liquid speed	10 m/s (see flow rate table)																
IP Degree of protection	IP68 IP68 continuous immersion at 1,5 m (IEC 529)																
Part in contact with the liquid	PTFE EBANITE																
Max Temperature	-40°C ÷ +180°C PTFE								-40°C ÷ +80°C EBANITE								
Flow pipe material	AISI 304 (Inox)																
Flange material	Carbon steel painted																
Electrodes material	Hastelloy C																
n° electrodes	3 (easy earthing discharge without ring on flange)																
Power supply	90-264 V (on request 24 V)																
Analogic output	0-20 mA																
Digital output	pulse/frequency 24 Vdc																
Display	2 line - 16 characters																
Net interface	RS 485																
According to standards	CEI EN61010-1 , EN50081-1 , EN50082-1 , UNI EN ISO 6817 , EN 1434 on request ATEX II 2GD EEx mb IIC T4 U																

Flow rate table (Blu figures are preferable)

DN	VELOCITA' [m/s] Velocity [m/s]			
	0,05	0,5	5	10
25	88,36 l/h	883,57 l/h	8.835,73 l/h	17.671,46 l/h
32	0,14 m ³ /h	1,45 m ³ /h	14,48 m ³ /h	28,95 m ³ /h
40	0,23 m ³ /h	2,26 m ³ /h	22,62 m ³ /h	45,24 m ³ /h
50	0,35 m ³ /h	3,53 m ³ /h	35,34 m ³ /h	70,69 m ³ /h
65	0,60 m ³ /h	5,97 m ³ /h	59,73 m ³ /h	119,46 m ³ /h
80	0,90 m ³ /h	9,05 m ³ /h	90,48 m ³ /h	180,96 m ³ /h
100	1,41 m ³ /h	14,14 m ³ /h	141,37 m ³ /h	282,74 m ³ /h
125	2,21 m ³ /h	22,09 m ³ /h	220,89 m ³ /h	441,79 m ³ /h
150	3,18 m ³ /h	31,81 m ³ /h	318,09 m ³ /h	636,17 m ³ /h
200	5,65 m ³ /h	56,55 m ³ /h	565,49 m ³ /h	1.130,97 m ³ /h
250	8,84 m ³ /h	88,36 m ³ /h	883,57 m ³ /h	1.767,15 m ³ /h
300	12,72 m ³ /h	127,23 m ³ /h	1.272,35 m ³ /h	2.544,69 m ³ /h
350	17,32 m ³ /h	173,18 m ³ /h	1.731,80 m ³ /h	3.463,61 m ³ /h
400	22,62 m ³ /h	226,19 m ³ /h	2.261,95 m ³ /h	4.523,89 m ³ /h

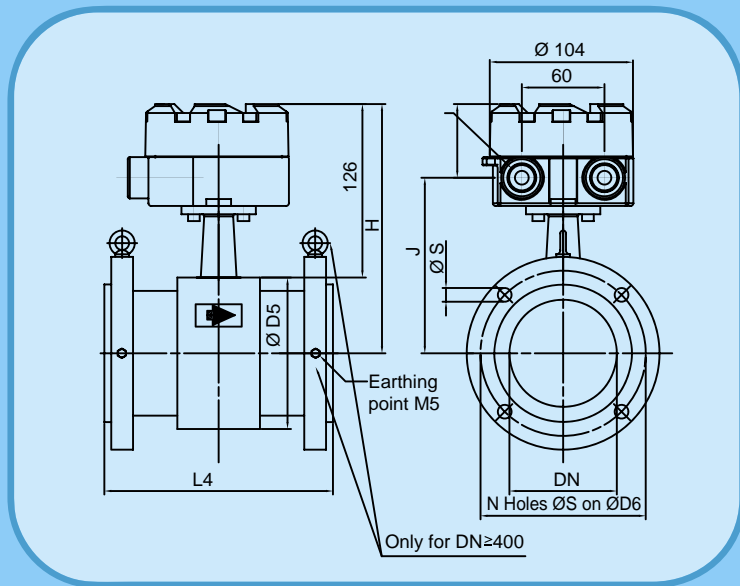

MAG-S

ØDN	ØD5	L4	J	ØD6	N	ØS	H
15	84	200 ⁰ / ₋₃	114.5	65	4	14	168
20	84	200 ⁰ / ₋₃	114.5	75	4	14	168
25	64	200 ⁰ / ₋₃	104.5	85	4	14	158
32	77	200 ⁰ / ₋₃	111	100	4	18	164.5
40	82	200 ⁰ / ₋₃	113.5	110	4	18	167
50	98	200 ⁰ / ₋₃	121.5	125	4	18	175
65	114	200 ⁰ / ₋₃	129.5	145	4	18	183
80	127	200 ⁰ / ₋₃	136	160	8	18	189.5
100	152	250 ⁰ / ₋₃	148.5	180	8	18	202
125	178	250 ⁰ / ₋₃	161.5	210	8	18	215
150	206	300 ⁰ / ₋₃	175.5	240	8	22	229
200	257	350 ⁰ / ₋₃	201	295	12	22	254.5
250	311	450 ⁰ / ₋₅	228	355	12	25	281.5
300	362	500 ⁰ / ₋₅	253.5	410	12	25	307
350	394	550 ⁰ / ₋₅	269.5	470	16	25	323
400	444	600 ⁰ / ₋₅	294.5	525	16	30	348

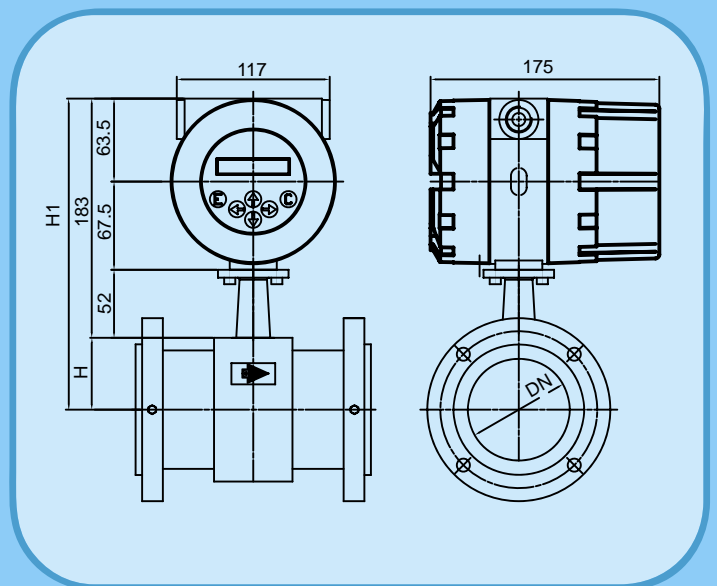

MAG-C

DN	H	H1
25	32	215
32	38.5	221.5
40	41	224
50	49	232
65	57	240
80	63.5	246.5
100	76	259
125	89	272
150	103	286
200	128.5	311.5
250	155.5	338.5
300	181	364
350	197	380
400	222	405

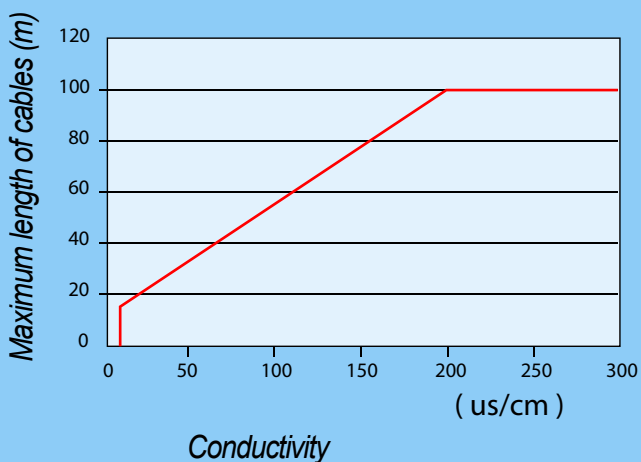

Maximum length of cables according to the liquid conductivity



Split model MAG-S